

Net weight: 51,00 kg
 Gross weight: 81,00 kg
 Volume: 0 m³

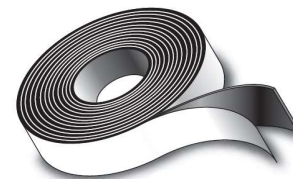

7 X 30 X 10000 A/60/PT3 PE-L - 0,33 szt

FO DC RH04 IE F - 1900832

Wymiary nadbudowy samochodowej - Dimensions of hardtop

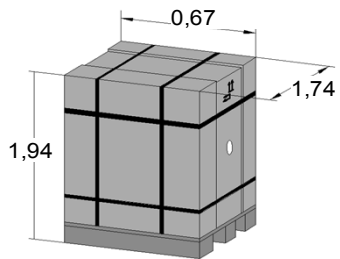
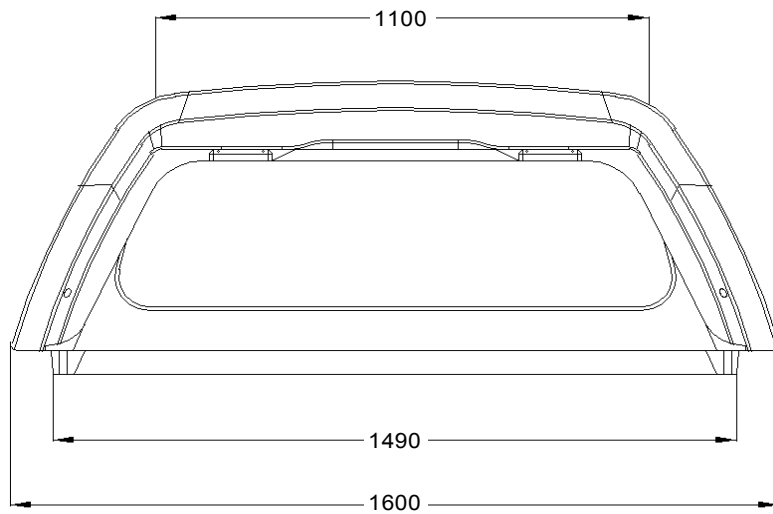
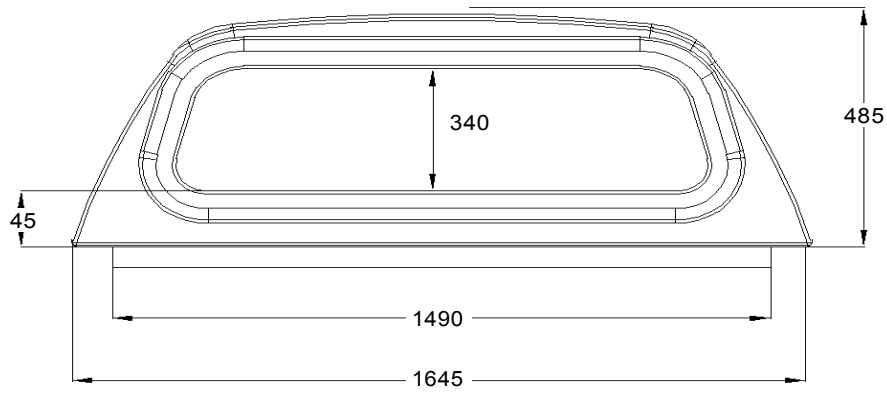

Net weight: 60,00 kg
Gross weight: 90,00 kg
Volume: 0 m3

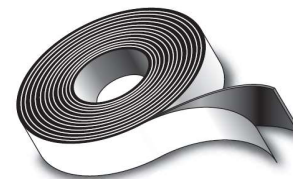
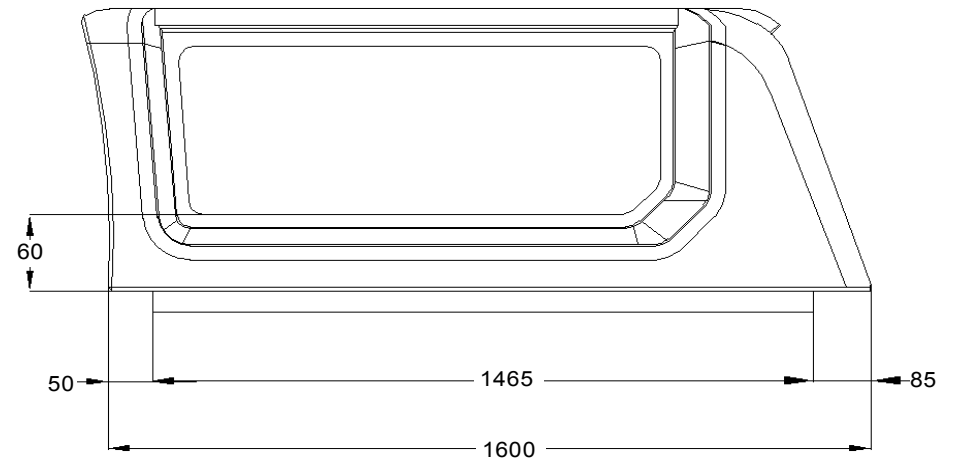
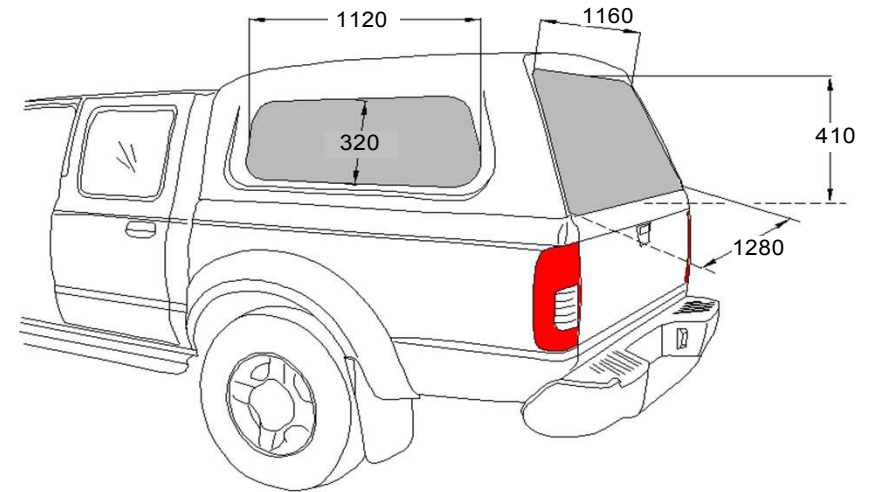

7 X 30 X 10000 A/60/PT3 PE-L - 0,33 szt

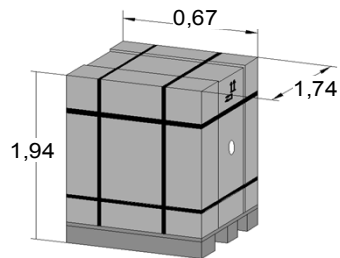
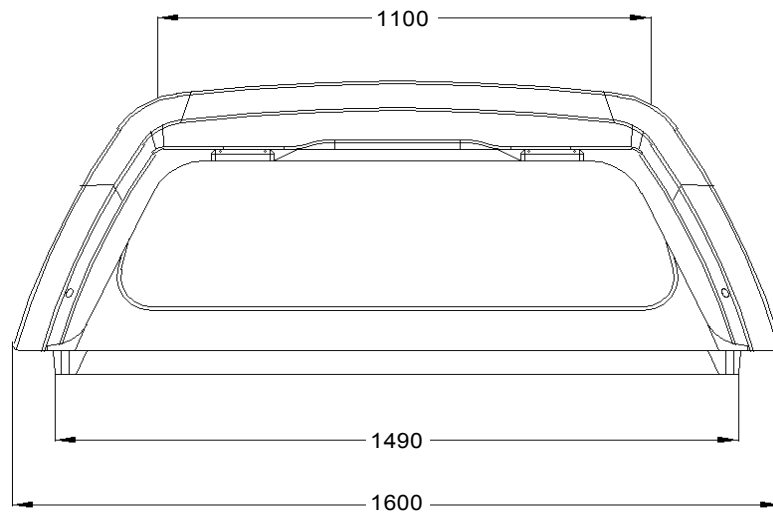
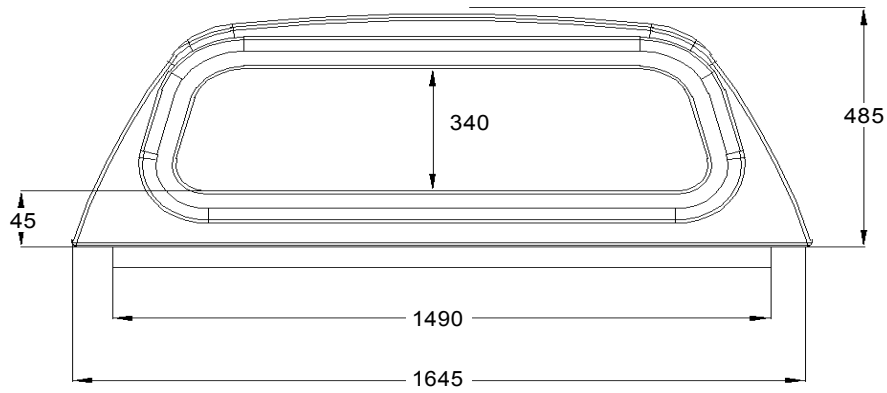

Net weight: 80,00 kg
 Gross weight: 110,00 kg
 Volume: 0 m3

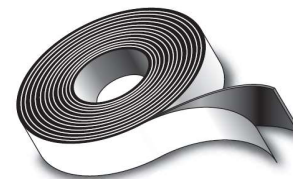
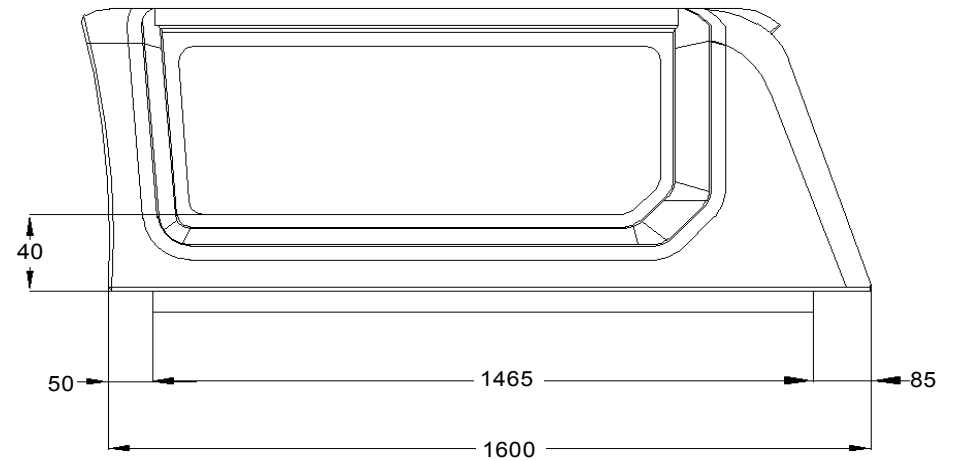
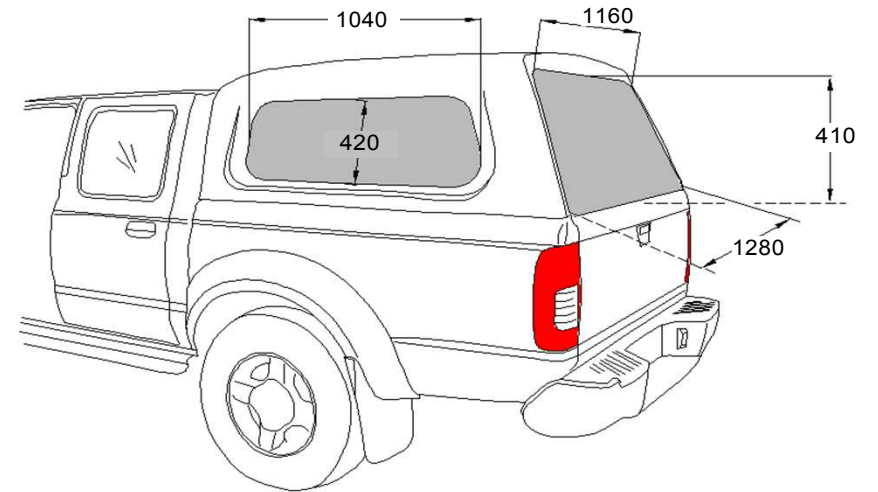

7 X 30 X 10000 A/60/PT3 PE-L - 0,33 szt

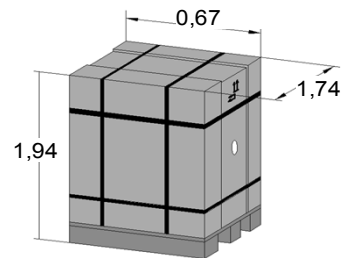
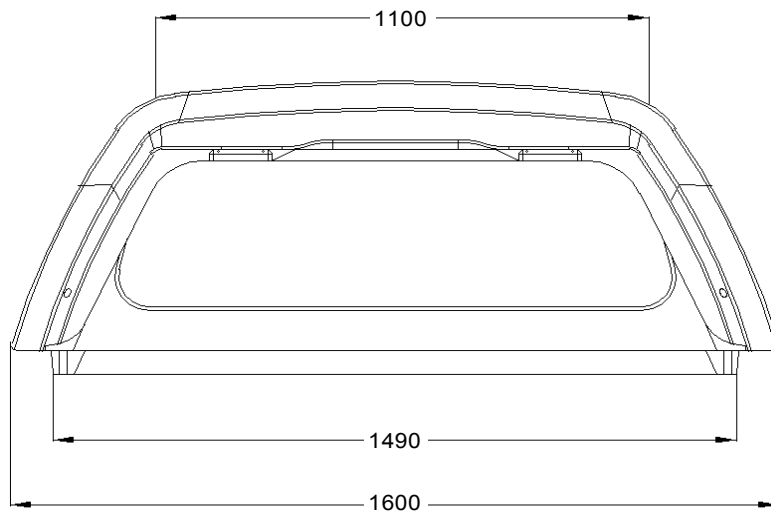
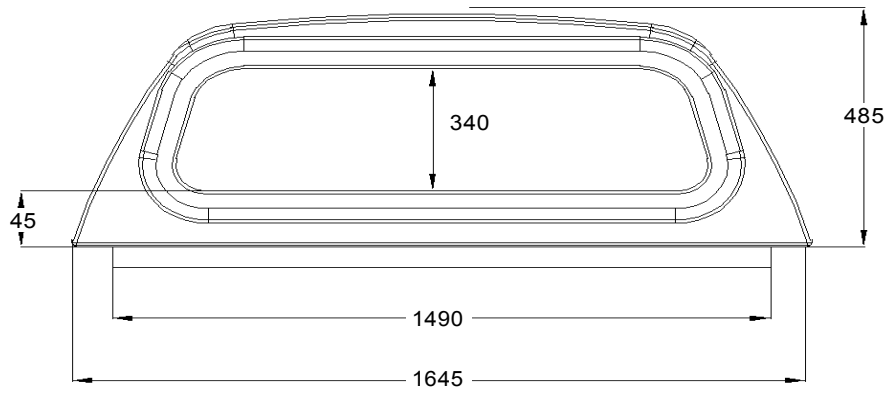

Net weight: 85,00 kg
 Gross weight: 115,00 kg
 Volume: 0 m3

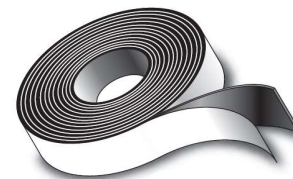
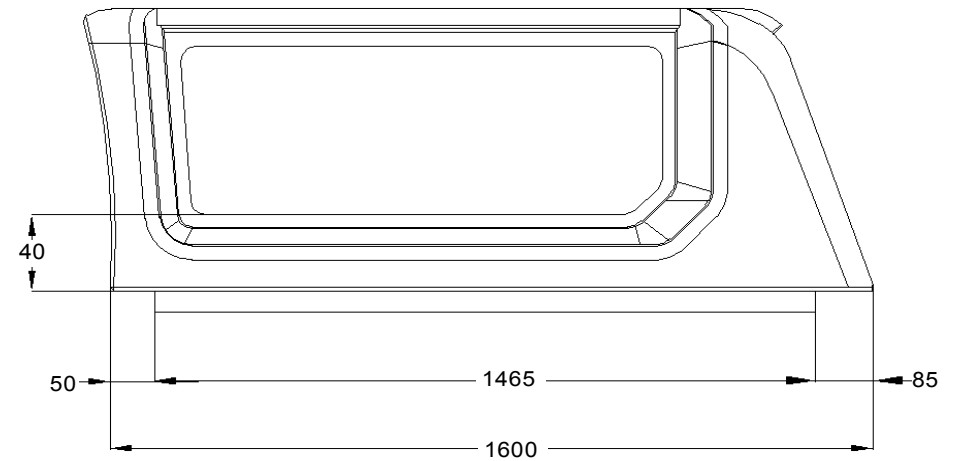
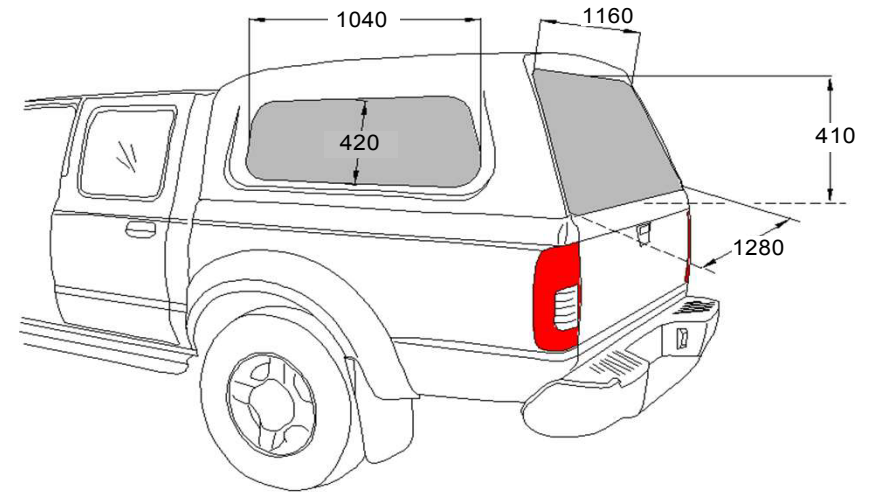

7 X 30 X 10000 A/60/PT3 PE-L - 0,33 szt